



# CV3

# Miktek™



Large Diaphragm  
Multi-pattern Tube  
Condenser Microphone

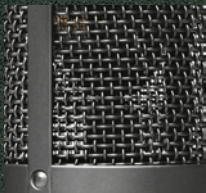

## Owner's Manual

Miktek, LLC

348 Valeria Street • Nashville, TN 37210

tel 615.250.2434 • fax 615.346.9298

©2010 -2013 All Rights Reserved, Miktek, LLC. Printed May, 2013 v1

**[www. miktekaudio.com](http://www.miktekaudio.com)**

Printed in China

# Table of Contents

|  |         |
|--|---------|
| <b>Introduction</b> . . . . .                | 3 - 4   |
| <b>Features</b> . . . . .                    | 5       |
| <b>Operating the CV3</b> . . . . .           | 6 - 10  |
| Using the Polar Patterns . . . . .           | 6       |
| Connecting your CV3. . . . .                 | 7       |
| Powering the CV3. . . . .                    | 7       |
| Setting Up the Signal Level . . . . .        | 8       |
| Microphone Placement. . . . .                | 8       |
| The Proximity Effect . . . . .               | 9       |
| Stand Mounting the CV3 . . . . .             | 9       |
| Installing the SM7 Shockmount . . . . .      | 10      |
| <b>Applications Guide</b> . . . . .          | 11 - 19 |
| Vocal . . . . .                              | 11      |
| Acoustic Guitar . . . . .                    | 12      |
| Piano . . . . .                              | 13      |
| Strings . . . . .                            | 14      |
| Overhead Drum Kit . . . . .                  | 14      |
| <b>Stereo Miking Techniques</b> . . . . .    | 15-19   |
| Coincidental - XY or Crossed pairs . . . . . | 16      |
| MS Mid-side . . . . .                        | 16-17   |
| Near Coincidental . . . . .                  | 18      |
| Spaced Pairs . . . . .                       | 18-19   |
| Baffled . . . . .                            | 19      |
| <b>Specifications</b> . . . . .              | 20 - 21 |

---

You've done, done it..... You've purchased a truly exceptional piece of audio gear! Congratulations and thank you for purchasing the CV3 Large Diaphragm Tube Condenser from Miktek. We know there are a lot of pretty good low cost microphones available today, but you're in an elite group of audio engineers where pretty good is just not good enough. Simply put, that's why we make our products.

In the following sections of this manual you will find a description of the CV3's features, step-by-step set-up and operating instructions along with detailed specifications. In addition, we've also included some basic miking techniques for typical recording and live sound applications. Most of us who've purchased the CV3 are already experienced engineers, so these may seem quite basic. However at Miktek, we want to encourage young or new engineers to use our microphones, or at least to read our manuals and learn something about recording and live sound. We know you're serious about your productions because you purchased such an outstanding audio instrument, and at Miktek, we're serious about providing superior products and service to our customers. We appreciate your patronage and hope you enjoy using your microphones as much as we enjoy making them.

Sincerely,

Michael Ketchell - Managing Director

---

## Introduction

The Miktek CV3 is a large-diaphragm tube condenser microphone offering nine pick-up patterns. The CV3's sound is truly large and produces a musical response that will please artists, producers and most seasoned engineers alike. The bottom end is big, warm and tight, with mids that are present and even, along with a high frequency response that's sweet and airy. The CV3 is ideal for recording single vocalists, and perfect for acoustic instruments, groups of vocals, piano, string ensembles, winds, overheads on a drum kit or as ambient room mics. The CV3 utilizes the MK9 capsule developed by Miktek. This unique capsule features dual 1-inch diaphragms manufactured using 5-micron Mylar with a 0.4-micron layer of evaporated gold, which is precisely tensioned, mounted to carefully-tuned backplates, and set back-to-back to create the final capsule. Tight tolerances and special attention to precise machining of the backplate produce a linear off-axis response that ensures the accuracy of the microphone. The CV3's electronic circuit design is unique and features the AMI T7 transformer together with the implementation of high quality, hand-selected exotic components. Together with an original NOS (new-old-stock) Telefunken EF800 tube, in which the high-voltage circuit has been uniquely implemented, the microphone challenges the performance of the best-in-class industry standards without hesitation. The Miktek CV3 is hand-built using components from the US, Europe and Asia, and is tested and packaged in Nashville, Tennessee, USA. Each microphone includes its serialized frequency response graph created during final testing. The CV3 is packaged with its swivel mount in a wooden box, which is set inside an aluminum case with the included power supply unit, 7-pin XLR cable and shock mount.

---

## Introduction

With proper care your CV3 will operate trouble free for many years. We recommend you record your serial number in the space provided below for future reference.

Serial number: \_\_\_\_\_

Date of purchase: \_\_\_\_\_

Be sure to complete the included warranty registration card or visit [mikekaudio.com](http://mikekaudio.com) to register on line. In the unlikely instance that your microphone would ever require service, please contact us at 615 250 2434 for a Return Authorization number. If you purchased the microphone outside of the US, please contact your local distributor for service. Please feel free to call us with any questions you may have about this or any other Miktek product.

---

## Features

- Classic Large-diaphragm Tube Condenser Design
- MK9 Dual 1-inch Capsule with 5-micron Mylar, Evaporated Gold Diaphragms
- Nine Selectable Pick-up Patterns; Omni , Cardioid, Figure-8 and transitional patterns in between each of those.
- Custom Miktek Transformer by AMI
- Subminiature Pentode Vacuum Tube
- Individual serialized Frequency Response Graph
- External Power Supply and 7-pin XLR Cable
- Wood Presentation Case with swivel-mount, shock-mount and rugged aluminum Carrying Case

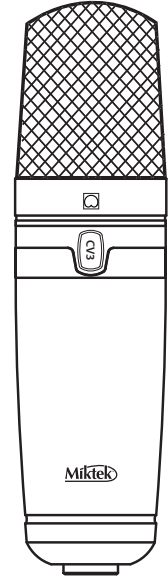
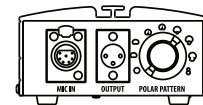

---

## Operating the CV3

### Using the Polar Patterns

Perhaps the most important aspect of using your CV3, or any other microphone, is to understand its available polar pick up patterns. Every microphone has a characteristic polar pattern that determines how well it accepts or rejects signal coming from various areas around the microphone capsule. You can use the CV3's polar pattern switch, located on the PS4 power supply's front panel, to select one of the available polar patterns. The CV3 provides nine polar pick-up patterns; omnidirectional, cardioid, figure-eight, plus transitional patterns in between each of those. This gives you a tremendous amount of versatility and sound possibilities. To understand the basics of patterns you need to know the three most common patterns; omnidirectional, bi-directional or figure-eight and cardioid. The omnidirectional pattern produces a linear response regardless of where the sound source originates (in front of the mic, behind it, to the side, etc.). If the talent needs to move around and has trouble staying in the same place in front of the mic, using the omni pattern can be extremely useful since the off axis change will have less of an effect on the frequency response. When the CV3 is set to the figure-eight pattern the microphone picks up sound directly from the front and back while rejecting the sound at the sides. When miking an acoustic guitar, a great way to capture some natural ambience is to set the mic in figure 8 and position it between a guitar and a reflective surface.

While Omni and Bi-directional microphones are very useful for a variety of applications, many miking situations in recording and live sound applications require uni-directional or cardioid microphones. When set to Cardioid, the CV3 will accept the sound coming from directly in front, and to reject sound coming from behind or from the sides. The cardioid pick-up pattern allows for better separation of instruments in the studio and more control over feedback in live sound reinforcement. When positioned correctly, the cardioid pattern allows you to pick up more of the sound you want and less of the sound you don't want. In live sound situations, the polar pattern also determines how prone a particular



---

## Operating the CV3

microphone is to inducing feedback. Feedback is that nasty howling sound that occurs when a mic is placed too close to a loudspeaker—the signal from the loudspeaker is fed into the mic, then into the loudspeaker, then into the mic, over and over again until an oscillating tone is generated. The cardioid pattern utilized by the CV3 is so good at rejecting signal not coming from directly in front of the microphone, you'll find that use of the CV3 greatly minimizes feedback problems when used in live sound applications.

### **Connecting your CV3**

To get started connecting the CV3, locate the included power supply and AC cable. With its POWER switch set to OFF, plug the AC cable into the back of the power supply, then plug the AC cable into an appropriate power outlet. Be sure to check the voltage switch is set to the correct voltage for your country. Next, connect the microphone to your power supply with the included 7-pin XLR cable. Be careful to line up the 7-Pin connectors so that you do not accidentally bend them. Now, connect the Mic Output on the CV3 power supply to your mixer's, mic pres or DAWs (Digital Audio Workstation) mic input using a standard XLR microphone cable. In order to ensure the proper phase response, please note the PS4's output connector is wired as Pin 1 Ground, Pin 2 hot or positive, and Pin 3 cold or negative.

Important Note: It's always a good idea to turn down your mixers main output level control when plugging or unplugging microphones so you can avoid any unwanted loud pops that could cause damage to your speaker system.

### **Powering the CV3**

Since the CV3 is a tube microphone it needs to be operated by connecting it to the included PS4 power supply unit as explained in the previous section. Once the power supply is connected to the microphone and mic input, power on the PS4 power supply. The Power switch illuminates indicating the microphone is on. You'll need to wait a bit for the tube to warm up and for the capsule bias circuit to reach the proper voltage. Also, it's normal for the CV3 to go off momentarily while switching through the patterns.

---

# Operating the CV3

## Setting Up the Signal Level

In order to get a good signal, first be sure that the CV3 is connected to a mixer or recorder input that is microphone level. As explained in the previous section “Powering the CV3”, be sure that the PS4 power supply is connected properly and turned on. Most quality mixers, mic pres and DAWs provide microphone inputs with a mic trim (“trim” is jargon. the control is usually called Mic Gain or Level) control. The purpose of the mic trim control is to set a good signal level and minimize any noise associated with the mic inputs electronics. A good mic pre will also have a Clip or Peak LED to show you when the input is at overload, the level at which distortion begins to occur. To set a good clean level, set the CV3 up in front of the desired sound source and slowly turn up the mic trim until you see the Clip LED light up. Then, turn the trim control down until the LED does not light any more. On most microphone inputs, the best setting is when the trim control is turned up as high as possible without lighting the PEAK LED.

## Microphone Placement

To help maximize the quality of your recording, you must pay careful attention to the placement of your CV3, and specifically, how it is positioned for the instrument or vocalist that you’re miking. Remember, the front side of the microphone is the same side as the Miktek logo. As you become more experienced in miking techniques, you’ll quickly realize the microphone placement is critical to getting the sound you want. For more information on typical miking, see the Application Notes section of this manual. But remember, these examples are at best an approximation of where you should place the microphone to get the best sound. While placing the mic around any instrument or sound source, monitor the signal through a set of good quality closed-back headphones and take notice to how just a slight adjustment can make a huge change in frequency response. As you’re changing the microphone’s position, be sure to check that the mic input is still set to a good level without clipping, as described in the previous section.

---

## Operating the CV3

### **The Proximity Effect**

All cardioid or uni-directional microphones exhibit a phenomenon known as “proximity effect”. The proximity effect is the increase in low frequency response a microphone exhibits as it is moved closer to the sound source. Vocalists tend to love this effect since when they get really close to the mic they get the “FM radio”, big bass sound. A good vocalist with good mic technique will use the proximity effect to adjust their tonal response in real time. The key to developing the best mic technique is experimentation along with awareness of the general principle that, when the pattern switch is set to Cardioid, and the closer your CV3 is to a signal source, the greater the bass response. The proximity effect’s bass lift is caused by the amount of pressure present at the ports that are used to create the directional pattern. Since omnidirectional microphones do not normally use these ports, they do not have proximity effect.

### **Stand Mounting the CV3**

The CV3 can be mounted to any standard microphone stand using the included mic stand holder or the SM7 shock-mount. If you are using a US standard 5/8-inch mic stand, remove the Euro adapter by unscrewing it from the mic holder. Screw the holder to a solid mic stand, then line up the bottom threaded section of the CV3 to the holder and slowly rotate the microphone clockwise until it screws on hand tight. Be careful not to cross thread the screws. You can loosen the bottom thumbscrew on the holder to make left and right adjustments to the mic, and then re-tighten it once it’s in place. Loosen the side thumbscrew to set the microphone angle and then tighten once it’s in place.

---

## Operating the CV3

### Installing the SM7 Shockmount

The CV3 kit comes with a SM7 shockmount, which you can use to greatly reduce any noise transmitted through the mic stand. The shockmounts are especially useful in reducing the problems caused by a boomy soundstage; for example when miking overhead cymbals, or even in the studio with talent that likes to move a lot on a floor that may not be as solid as it should be.

- To use the CV3 with its included shockmount, screw the shockmount on a solid mic stand. If you are using a US standard 5/8-inch mic stand, remove the Euro adapter by unscrewing it from the shockmount.
- Once the shockmount is mounted to the stand, line up the bottom threaded section of the CV3 to the holder and slowly rotate the bottom thumbscrew clockwise until it screws on hand tight. Be careful not to cross thread the screws.
- You can loosen the bottom thumbscrew slightly to make left and right adjustments to the mic, and then re-tighten it once it's in place. Remember, the front side of the microphone is the same side as the Miktek logo.
- Loosen the thumbscrew to set the microphone angle and then tighten once it's in place.

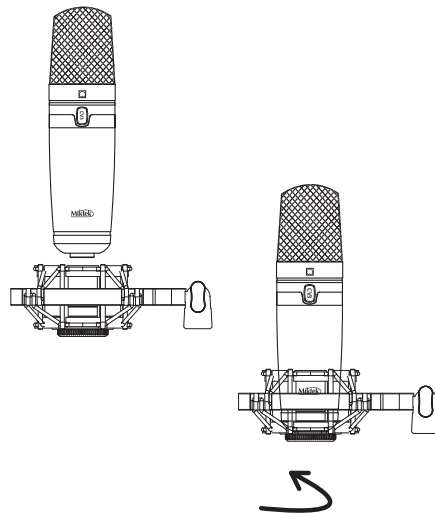

---

## Applications Guide

The CV3 is a great microphone choice for many instrument miking situations. Below is a brief guide on using the CV3 in some typical applications. But as a general rule of thumb, before you use a typical placement, carefully listen to what you are miking by having the artist play a practice track. Take a walk around the artist as they are playing and listen to what the instrument sounds like from different positions. Move left and right. Listen over the artist's shoulders. Place your head up high and close to the floor. Imagine your ears are the microphones. What do you hear that you like? Then, once you choose your spot, monitor the signal through a set of good quality closed-back headphones and take notice to how just a slight adjustment can make a huge change in frequency response. However, before you get into experimenting, the following basic examples are a good place to start.

### **Vocals**

When using the CV3 on vocals, position the microphone with the logo facing in front of the artist and so that the microphone grill is approximately 4 to 10 inches away. To avoid unwanted p-popping, use of an external pop filter is strongly recommended. If no pop filter is available try to set the microphone at a slight angle, which will also help reduce p-pops. When the CV3's pattern switch is set to Figure eight, you can record a vocal duet by positioning one vocalist directly in front of the mic and one directly facing the rear of the microphone. Just remember that the extreme sides of the microphone pick up almost nothing due to the bi-directional pick up pattern. You can record a group of vocalists by positioning them in a circle around the CV3 with the pattern switch set to Omni. The linear response will evenly pickup up all the vocalists in a 360 degree pattern. Try to set the balance by having the talent use natural dynamics to blend, or position each singer at different distances to the mic to create a different balance.

---

## Applications Guide

### Acoustic Guitar

There are a variety of ways that the CV3 can be used to mic an acoustic guitar. The correct placement will depend on the type of instrument and what kind of sound you're looking to capture, for example the tonal quality you want to focus on, and how much finger slide or pick noise you may or may not want. When miking a standard steel string acoustic, a good place to start is with the microphone positioned pointing towards the end of the fingerboard at a distance of about 6 inches to 2 feet away from the instrument. You can experiment by moving the microphone slightly in the direction of the sound hole, which will produce more low frequencies, or move it in the direction of the 12th fret to capture more high-end or to remove any unwanted boominess. For nylon string acoustic, try positioning the microphone above the bridge to emphasize more of the attack from the sound of the finger picking, or for less, move the mic closer to the sound hole. If you have a pair of CV3's, try one positioned at the fingerboard and the second over the sound hole. Try positioning one mic in the front of the guitar pointed towards the fingerboard and another over the right shoulder (right handed player).

***Important Note:*** *When using multiple microphones you need to be aware of their phase response. In general, all the microphones need to be facing in the same direction or you will experience comb filtering and/or phase cancellation. For instance, in the previous example set up it will be necessary to invert the phase on the over the shoulder microphone since it will more than likely end up facing the opposite direction as the front microphone. Any good mic pre will have a Phase reversal switch so be sure to reverse the phase of any mics facing the opposite direction.*

### Piano

You can achieve outstanding results using the CV3 on acoustic piano. Several placement approaches can be used depending on the size of the piano, and the type of sound you are looking to record. When miking a Grand Piano, (for an ambient sound like that used in a classical recital), a single CV3 can be positioned directly in front of the instrument. Open the lid to the full position and place the microphone five to twelve feet in front of the instrument. For a more contemporary sound with better isolation, place two CV3's inside the piano positioning one over the low strings and the other over the high strings. To achieve a more realistic sound, it's a good idea to leave some space between the instrument and the microphone, especially if you are recording a solo instrument. Also, keep in mind how the track ultimately needs to fit into the mix. For example, if you are recording a solo performance of Chopin, you would likely want a very even response and you'd want to capture the left hand sostenuto. However, if you are recording rock and roll or pop music, you may want the piano to sit within the track in a specific frequency range where less bass is desired. Nashville engineers, and other good ones from all over the planet, are famous for building the mix as they track, starting with the microphone placement. You can also try the XY or ORTF stereo mic set-ups described in the following section, "*Stereo Miking Techniques*".

---

## Applications Guide

### Strings

Place the CV3 one to three feet from the instrument when recording a solo string instrument like a violin. When recording a string section, try to position one or more CV3's several feet from the players. If the size of the room permits, raise the microphones three or four feet above the section and position them at a 45-degree angle, facing down. If you have two CV3's, you can try the XY or ORTF stereo mic set-ups described in the following section, "*Stereo Miking Techniques*".

### Overhead Drum Kit

Because of its linear, full range frequency response, the CV3 performs outstandingly when used as an overhead cymbal microphone. The CV3's big sound and linear response capture the entire kit making them awesome on overheads. You can position one CV3 on a boom mic stand directly above the kit pointing from front to back. For stereo miking, use two CV3's placed over the drum set at a distance of two to three feet depending on the size of the kit. You can experiment with the exact placement depending on the size of the room and whether you're looking for an ambient or close-miked sound. You can also try the XY or ORTF stereo mic set-ups described in the following section, "*Stereo Miking Techniques*". In general, when miking a drum kit, it's a good idea to start with the overhead mics. Even though you use the overhead mics mostly for the cymbals, try to get the entire kit to sound great in the overheads. Then it will be easier to just bring up your individual mics for more attack and thickness in the overall sound.



---

# Stereo Miking Techniques

## Stereo Miking Techniques

Recording instruments like acoustic guitar, piano and drums, or ensembles (especially in classical or jazz), in stereo will provide a much more realistic experience for the listener. You can create a stereo recording by simply using your mixer's or DAW's pan controls to place different instruments in between the left and right speakers. However, since the recorded tracks were likely created with close miking, the stereo mix is void of a lot of information that the listener would normally enjoy in a live performance. When you record live tracks in stereo, not only will you capture the left and right position, but you can capture the perspective of depth and distance of each instrument. You'll also capture an image that translates the distance between the ensemble and the listener, and, you capture the sound of the acoustic space surrounding the instrument or ensemble. When recording ensembles in stereo you have better chance of faithfully reproducing the balance between the instruments that was originally intended by the composer. For most stereo miking applications, you need to have two microphones with closely matching frequency responses and polar patterns. Depending on which miking technique you use, the stereo image is created when the combination of microphones pickup differences in level, time and frequency response.

There are several time-tested techniques for recording in stereo including coincidental or XY pairs, near coincidental or AB, spaced pairs, and baffled. Following is a brief explanation of these common types of stereo miking set ups.

---

## Stereo Miking Techniques

### Coincidental - XY or Crossed pairs

Coincidental microphone set ups are where the two microphones' capsules are set close together on the same axis. The most common of these is XY or crossed pairs. In the XY set up, the two microphone capsules are positioned on the same axis, one directly above the other with the capsules positioned on an angle from 90 to 120 degrees. The wider the angle, the wider the stereo spread. Since the microphones are set on the same axis, the distance is constant and there's little or no delay difference. Therefore, the stereo image is created by the level difference of the left and right microphones. Since there is no appreciable delay, there is less of a chance for phase cancelation and comb filtering so you can get good results when the stereo signal is combined to a mono signal.

### MS - Mid side

The Mid side technique makes use of two microphones, with one figure-8 and a second mic either cardioid or omni, or two figure-8 pick patterns. The first microphone (the mid), either figure-8, omni or cardioid microphone, is positioned facing directly at the sound source. The second microphone (the side), with a figure-8 pattern, is positioned on the same axis directly

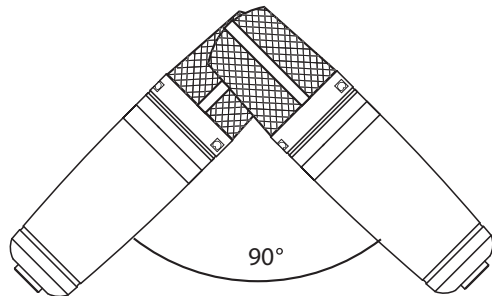

---

## Stereo Miking Techniques

above or below the first, but with the capsules positioned at a 90-degree angle from the front. The outputs of the two microphones are often connected to a special MS matrix mixer, which combines the mid signal with the signal of the side microphone, both in phase and out of phase. The matrix mixer's ratio control is now used to set the balance between the mid mic and the combined signal of the side mics to adjust the width of the stereo spread. You can also connect the two microphones outputs to two inputs of a stereo mixer, let's say channel one and two. Next, split the side signal into a third channel set to reverse phase. Pan channels two and three hard left and hard right respectively. Channels two and three should be at equal level and always adjusted the same amount as if they were grouped together. Now use the balance between channel one and the grouped channels two and three to adjust the width of the stereo spread. If you want to create the Mid-side stereo effect after you've recorded into your DAW, record the mid mic on track one, and the side mic on track two. Then, copy track two to track three, be sure they are aligned perfectly and then reverse the phase on track three. Now group tracks two and three together so they move with one fader. Then pan channel two hard left and channel three hard right. At this point you can adjust the width of the stereo image by changing the balance between track one and the group channels two and three.



Figure-8

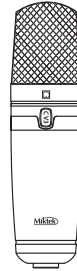

Cardioid

---

# Stereo Miking Techniques

## Near Coincidental

Near coincidental or AB mic set up use two matched microphones set relatively close together, facing in opposite directions. The spacing between the microphones creates a time delay adding to the stereo effect. The greater the angle the greater the stereo spread. Less of an angle yields a more narrow spread. There are a few standards that specify different angles and spacing, with the most popular being the ORTF (the acronym given to the French Broadcasting Organization which stands for Office de Radiodiffusion Television Française). The ORTF standard specifies the capsules to be spaced 17cm apart and set at a 110-degree opposing angle. In this setup the stereo image is created by the differences between level and time. The stereo image is sharp however it tends not to be mono compatible.

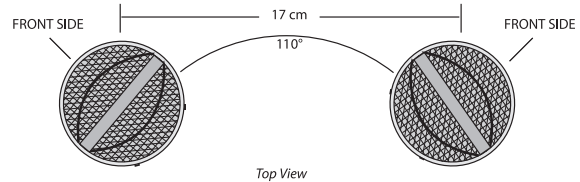

## Spaced Pairs

The spaced pair approach uses two identical microphones set rather far apart, for example 2 to 20 feet, or more apart, both facing directly at the sound source. The further apart that the microphones are placed, the wider the stereo spread.

---

## Stereo Miking Techniques

The instruments in the center of the two microphones will be heard midway between the left and right speaker. With greater distance, the off center images are less focused or more diffused. This set-up tends to capture more ambience from the acoustical space, which can be very pleasant to the listener, however the signal tends not to be mono compatible. In some instances where the microphones are very far apart, a third microphone can be used in the center to reinforce the clarity of the center image.

### Baffled

In a baffled stereo set up, two omni directional microphones are placed roughly the distance between your left and right ears with a physical hard or foam baffle placed in-between the two mics. It uses time differences at low frequencies and level differences at high frequencies to create the stereo image. The baffle creates a difference in frequency response between the two microphones, with less high frequency content heard from the further microphone. Therefore with the baffled set-up, the stereo signal is achieved by the combination of the differences in level, time and frequency. With the baffled set-up the stereo image has a tendency to be exaggerated and not mono compatible.

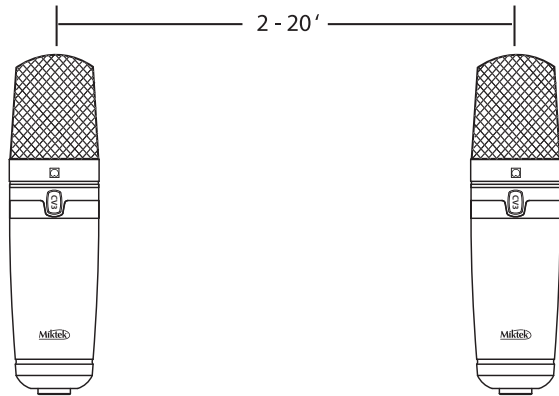

# Specifications

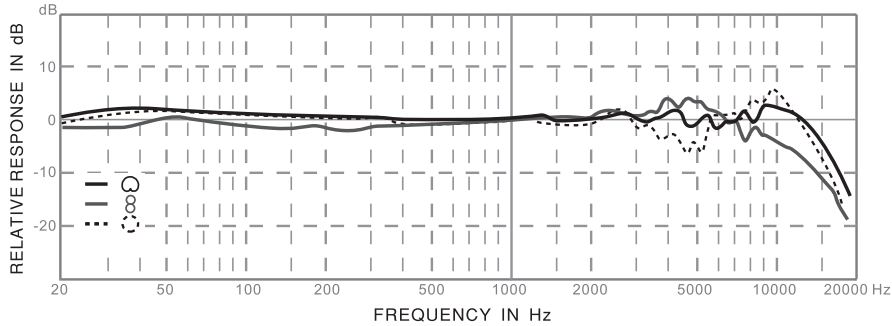

*CV3 Typical Frequency Response*

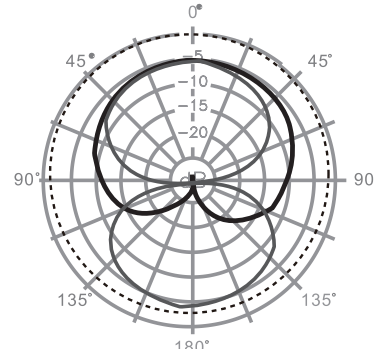

*CV3 Polar Response*

---

## Specifications

|                                    |  |
|------------------------------------|--|
| ■ Type . . . . .                   | Large Diaphragm Nine-Pattern Tube Condenser  |
| ■ Polar Patterns . . . . .         | Nine Selectable; Omni, Cardioid, Figure-8 and a transitional patterns in between each of those |
| ■ Frequency Response. . . . .      | 20~20000Hz   |
| ■ Sensitivity . . . . .            | -35 dBV/Pa   |
| ■ Equivalent Noise Level . . . . . | 16 dB  |
| ■ Dynamic range. . . . .           | 117dB  |
| ■ S/N Ratio . . . . .              | 78dB   |
| ■ Max. SPL . . . . .               | 133 dB   |
| ■ Power Supply . . . . .           | Miktek PS4   |

*Specifications are subject to change without notice.*

**[www. miktekaudio.com](http://www.miktekaudio.com)**

**348-B Valeria Street • Nashville, TN 37210**  
**tel 615.250.2434 • fax 615.346.9298**

©2009 All Rights Reserved, Miktek. Printed May, 2010 v1