

e608

Bedienungsanleitung
Instructions for use
Notice d'emploi
Istruzioni per l'uso
Instrucciones para el uso
Gebruiksaanwijzing

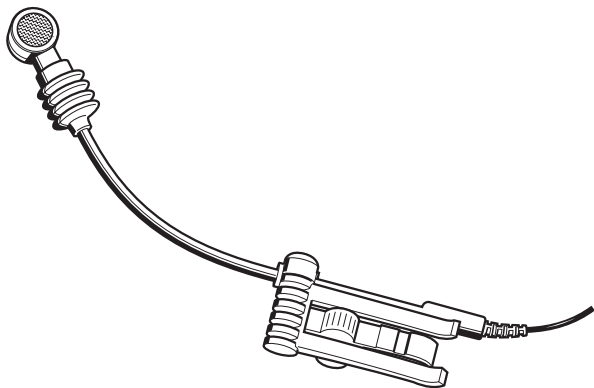

 **evolution**

e608

The super-cardioid **e608** is a dynamic microphone ideal for almost invisible clip-miking of drums, percussions, brass and woodwind (except certain flutes). The goose-neck mounting enables the capsule to be positioned close to the signal source for high realism and high-level output.

Extensive damping and shock mounting isolates the capsule and signal from extraneous vibrations, impact and handling noise. The humbucking coil protects against electromagnetic interference.

Features

- Rugged reinforced glass-fibre body
- Shock-mounted capsule provides low sensitivity to impact and handling noise
- Humbucking coil
- Extremely robust connection cable with XLR-plug

Delivery includes

- **e608** microphone
- Microphone clamp MZQ 800
- Connection cable
- Pouch
- Instructions for use
- Warranty Certificate

Positioning the microphone

Wind instruments

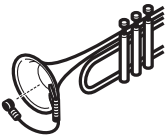
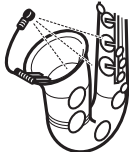
Position	Resulting sound	Commentary
	Reduced ambient noise	Use the supplied clamp to attach the microphone to the bell of the instrument.
	Clear, powerful sound	
	Balanced, natural sound	For a Saxophone, the microphone should normally be directed partly towards the bell and partly towards the body of the instrument.

To reduce ambient noise (at the expense of the true “Saxophone sound”) direct the microphone into the bell. In order to prevent interference due to crosstalk between adjacent sound sources, try to position the microphone so that the interfering sound source is located in the angle area of the highest cancellation of the microphone (approx. 120°; see polar diagram).

Polar diagram

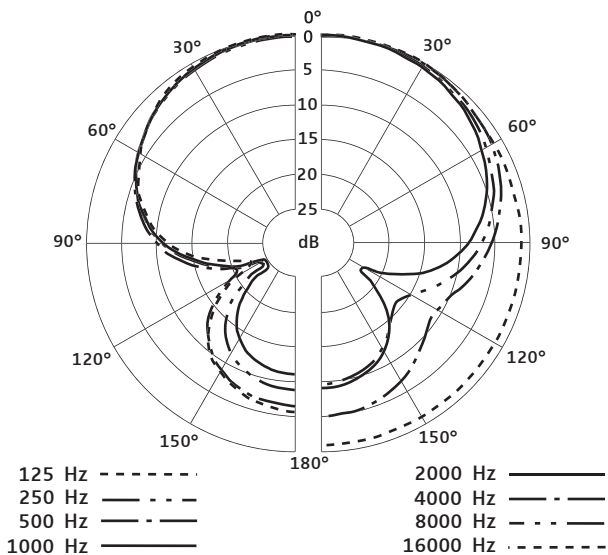

Frequency response curve

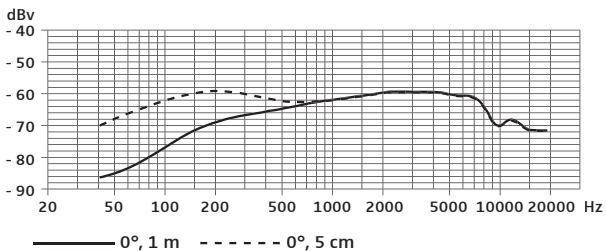

Specifications

Transducer principle	dynamic
Frequency response	40.....16,000 Hz
Pick-up pattern	super-cardioid
Sensitivity (free field, no load) (at 1 kHz)	0.8 mV/Pa
Nominal impedance (at 1 kHz)	250 Ω
Min. terminating impedance	1 k Ω
Connector	XLR-3
Connection cable	3 m, with XLR-plug
Dimensions	\varnothing 17 x 185 mm
Weight	20 g

Pin assignment of XLR-3 connector

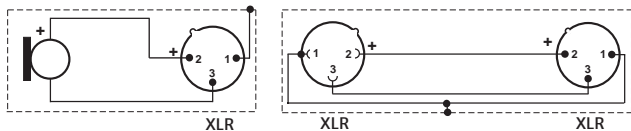

Overview of microphone applications

Application	Variant										
	e602-II	e604	e606	e608	e614	e815	e825	e835	e840	e845	e865
Vocals						x	x	x	x	x	x
Choirs					x						
Studio, acoustic instruments					x						
Orchestra					x						
Brass / Saxophone	x	x		x							
Acoustic guitar					x						
Acoustic bass					x						
Guitar amplifiers			x								
Bass amplifiers	x										
Leslie	x	x	x								
Piano, grand piano					x						
Kick drums	x										
Snare drums		x	x	x							
Rack toms		x	x	x							
Floor toms	x	x	x								
Congas		x	x	x							
Cymbals					x						
Percussion		x	x	x	x						
Overheads					x						

Manufacturer declarations

Warranty

2 years

Approval



Sennheiser electronic GmbH & Co. KG declare that this device is in compliance with the applicable CE standards and regulations.

WEEE Declaration



Please dispose of this product at the end of its operational lifetime by bringing it to your local collection point or recycling centre for such equipment.





Sennheiser electronic GmbH & Co. KG
30900 Wedemark, Germany
Phone +49 (5130) 600 0
Fax +49 (5130) 600 300
www.sennheiser.com

Printed in Germany

Publ. 01/07

094285/A02